

GUBT Range of Flameproof EExd IIC T6 Junction Boxes



Application

GUBT Flameproof Junction Boxes are intended for use in areas made potentially hazardous by the presence of flammable liquid, dust, gas or vapour (Zone 1 or Zone 2).

Features

- Full Certificate of Conformity for Group IIA & IIB & IIC (Hydrogen) areas.
- Manufactured in a range of 5 sizes (table 1), for varying number of terminals with different current rating (table 2).
- Protection grade IP66 to EN 60529 by application of an approved non-hardening grease and "O" ring seal for added resistance to the ingress of dust and moisture. IP67 on request.
- Internal / external earth stud size M6.
- Entry thread forms standard ISO 965.1 metric. Other thread forms supplied on request.



Material

Body and cover	-Copper free aluminium alloy LM25 (BS 1490)
Hardware	-Standard: Steel zinc plated Optional: Stainless steel.



Finish

Standard:	Two coat of Gray oven backed.
Optional:	Two pack epoxy paint, or electrostatic powdercoated

Approvals

CENELEC Standards EN 50014 / 50018
ISSeP Certificate of conformity
96D.103.1240 EExd IIC T6

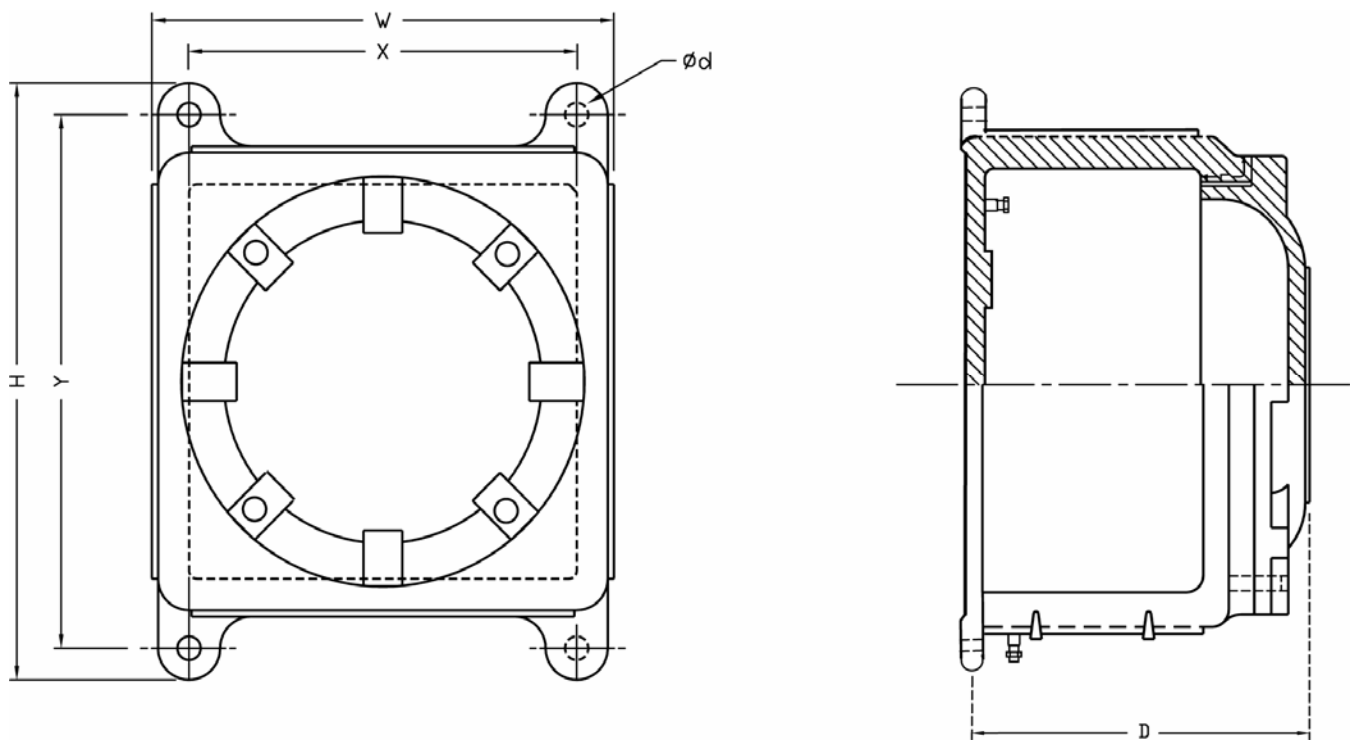

Table 1. GUBT range of enclosures and dimensions (in mm)

ENCLOSURE	OVERALL DIMENSIONS			MOUNTING DETAIL				WEIGHT KGS.S
	CAT NO.	W	H	D	X	Y	d	
GUBT1	129	167	120	97	151	M8	2	2.8
GUBT2	157	197	135	125	174	M10	2	4.0
GUBT3	180	211	140	150	193	M10	2	4.5
GUBT4	252	289	174	217	260	M10	2	10.0
GUBT5	318	379	245	275	337	M14	4	18.0

Table 2. Terminal characteristics / No. of Poles

Terminal Current (Amps)	Maximum No. of Terminals Per Enclosure				
	GUBT 1	GUBT 2	GUBT 3	GUBT 4	GUBT 5
Up to 27	10	14	17	46	90
Up to 36	10	13	16	42	78
Up to 47	8	10	13	34	66
Up to 65	6	8	10	28	54
Up to 87	5	7	9	11	30
Up to 145	4	4	5	8	10
Up to 220	8
Up to 265	6
Up to 415	3
Up to 600	3

نور محور فارس

NM SWITCHGEAR

P. O. Box : 71955-441, Shiraz, Iran

Tel. +98 711 630 1096, Fax +98 711 630 7725

www.nmswitchgear.com, info@nmswitchgear.com

- Specify cable diameter and thread forms on ordering.
- Specify any optional accessories, if required.
- Design is subject to alteration without notice.