

# Floodlight Projector

Flame proof ( Type d )

NMFL Series



## Application

NMFL Flameproof floodlight projectors, 250 and 400 watts, are intended for use in areas made potentially hazardous by the presence of flammable liquid, dust, gas or vapor ( zone 1 or zone 2 ).

For installation at petroleum refineries, chemical and petrochemical plants, marine locations and other process industries where a similar hazard exists.

## Features

Full certificate of conformity for group IIC areas

Used with incandescent or discharge lamps

GUBC boxes, with power unit and capacitor mounted inside, are connected to floodlight by conduit or cable

Supplied with heat resistant tempered glass sealed onto a threaded metal base

Designed to be installed in any horizontal or vertical direction

Reflector mounted inside the body

Internal & external M6 earth stud supplied as standard

E40 size lampholder on both 250 & 400 watts.



CE ATEX

**Material :** Copper free aluminium alloy (BS1490)

**Finish :** Aluminium: natural  
Two pack epoxy paint, or electrostatic powder coated

**Approvals:** IEC 60079-1 & IEC 61241-1  
ISSeP Certificate No. ISSeP09ATEX012

 Ex d IIC T4 IP66

NM SWITCHGEAR

نور محور فارس

LAMP	INCANDESCENT / BLENDED	HIGH PRESSURE MERCURY		HIGH PRESSURE SODIUM		METAL HALIDE	
		WATTS	250	400	250	400	250
POWER UNIT TYPE	-----	GUBC 34	GUBC 4	GUBC 34	GUBC 4	GUBC 34	GUBC 4
EQUIPMENT	-----	BALLAST 250 W	BALLAST 400 W	BALLAST 250 W	BALLAST 400 W	BALLAST 250 W	BALLAST 400 W
		CAPACITOR 20 $\mu$ F	CAPACITOR 30 $\mu$ F	CAPACITOR 35 $\mu$ F	CAPACITOR 50 $\mu$ F	CAPACITOR 35 $\mu$ F	CAPACITOR 35 $\mu$ F
				IGNITER	IGNITER	IGNITER	IGNITER

DIMENSIONS ARE IN mm.

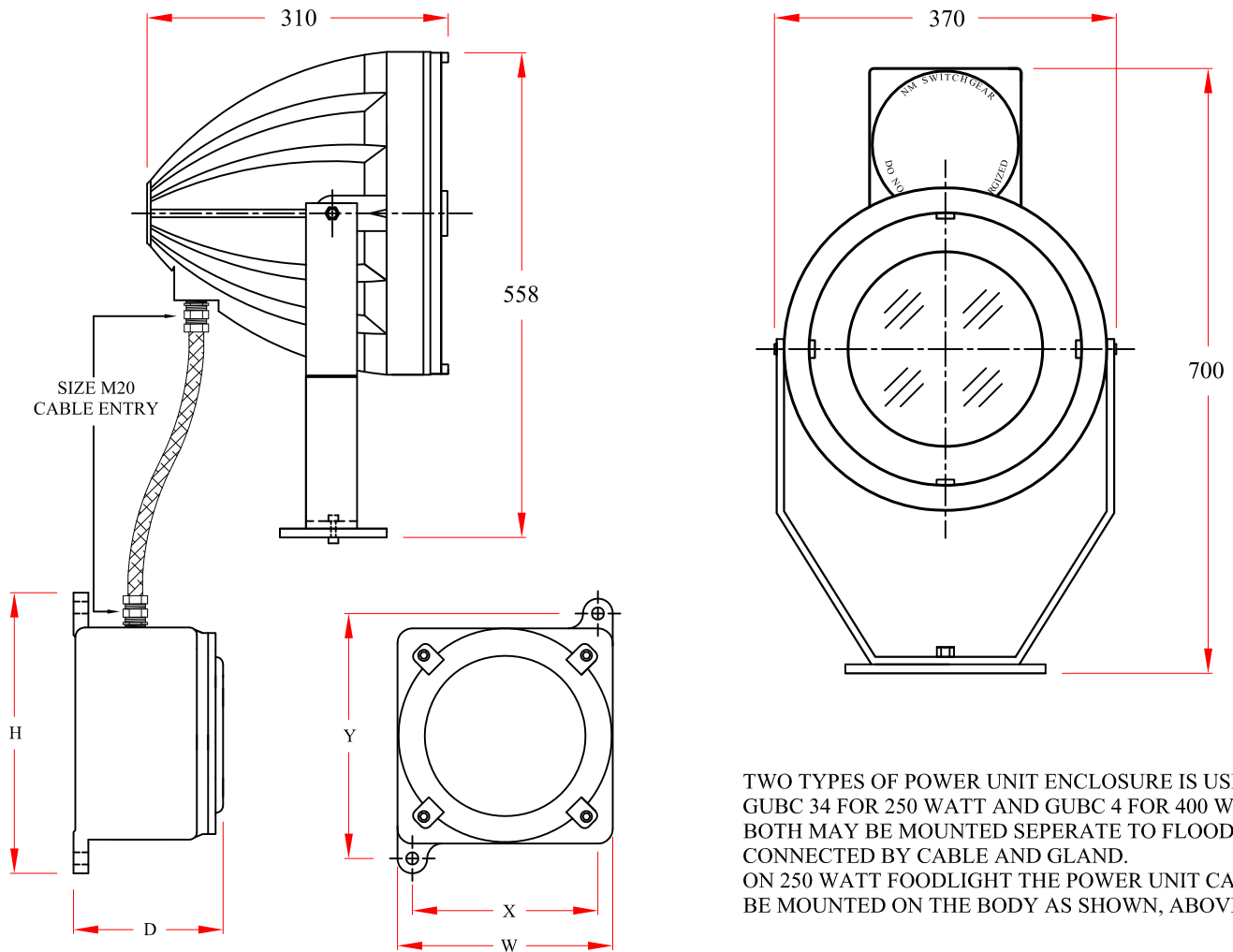

TWO TYPES OF POWER UNIT ENCLOSURE IS USED. GUBC 34 FOR 250 WATT AND GUBC 4 FOR 400 WATT. BOTH MAY BE MOUNTED SEPERATE TO FLOODLIGHT CONNECTED BY CABLE AND GLAND. ON 250 WATT FOODLIGHT THE POWER UNIT CAN ALSO BE MOUNTED ON THE BODY AS SHOWN, ABOVE.

	W	H	D	X	Y
GUBC34	200	200	150	205	207
GUBC4	252	289	174	217	260

## NM SWITCHGEAR

P.O.Box 71955-441, Shiraz, Iran  
 Tel. +98 711 630 1096, Fax +98 711 630 7725  
[www.nmswitchgear.com](http://www.nmswitchgear.com), [info@nmf.ir](mailto:info@nmf.ir)

- Specify installation type and cable entry on ordering.
- Specify any optional accessories, if required.
- Price and design are subject to alteration without notice.
- All products sold subject to our terms and conditions of business.